

DI-158 Series of Starter Kits

Low Cost, Compact Data Acquisition Kit

Convenient USB Interface

Four $\pm 10\text{V}$ or $\pm 64\text{V}$ Analog Fixed Differential Inputs

Four General Purpose Digital Inputs

Supports Sample Throughput Rates up to 14,400 Hz

12-bit Resolution

DI-158 products break new ground in price and performance, offering advanced features and options usually reserved for more expensive instruments. A channel scan list, high sample throughput rates, and an advanced computer interface are just some of the features combined to produce a robust instrument that can be applied to nearly any data acquisition situation where low and high level signals need to be acquired to a PC.

The high level gain/high full scale range option provides gain ranges of 1, 2, 4, 8, 16, 32, 64, 128, 256, and 512 with a full scale range of ± 64 volts. The standard model provides gain ranges per channel of 1, 2, 4, and 8 with a full scale range of ± 10 volts. Units are powered through the USB interface so no external power is required.



Features

Easy to Connect and Use

The convenient USB interface allows the DI-158 to connect to any local laptop or desktop PC. Power is derived from the PC through the USB interface so no external power is required.

Two, built-in, 8 position screw terminal connectors allow easy and secure access to all DI-158 signal I/O connections without the need for extra options.

High Resolution

12-bit measurement resolution provides a responsive instrument capable of registering changes as small as one part in $2,048 \pm 0.05\%$ of the full scale measurement range.

Wide Sample Throughput Range

Throughput ranges from sub-Hertz to up to 14,400 Hertz allow the DI-158 to connect to a wide range of both static and dynamic signals.

Compact

Small size— $66\text{D} \times 66\text{W} \times 28\text{H}$ mm ($2.6\text{D} \times 2.6\text{W} \times 1.1\text{H}$ inches)—allows the DI-158 to fit comfortably in crowded instrumentation cabinets, desktops, and other tight locations.

Built-In Channel-Gain Scan List

The Built-in channel-gain scan list eliminates unpredictable channel skews and allows channels to be selectively enabled or disabled to match your application. It also allows channel gain to be dynamically selected per channel during scanning to precisely match signal requirements on a channel by channel basis.

Built-In, Bidirectional Port

Built-in bidirectional port allows programmable discrete inputs and outputs for control.

Free Data Acquisition Software

Our WINDAQ/Lite data acquisition software offers real-time display and disk-streaming for the Windows environment. The real-time display can operate in a smooth scroll or triggered sweep mode of operation, and can be scaled into any unit of measure. Event markers with comments allow you to annotate your data acquisition session as you're recording to disk.

Raise your productivity to new heights with WINDAQ's unique multitasking feature. Record waveform data to disk in the background while running any combination of programs in the foreground — even WINDAQ Playback software to review and analyze the waveform data as it's being stored!

Specifications

Analog Inputs

Number of Channels: 4

Channel Configuration: Fixed Differential

Measurement range (Full Scale), Accuracy, and Resolution

	Gain	Range	Accuracy	Resolution
DI-158U:	1	±10V	±.25% of FSR	±4.88mV
	2	±5V	±.25% of FSR	±2.44mV
	4	±2.5V	±.25% of FSR	±1.22mV
	8	±1.25V	±.25% of FSR	±0.61mV
DI-158UP: (models with programmable high gain option)	1	±64V	±.25% of FSR	±31.3mV
	2	±32V	±.25% of FSR	±15.6mV
	4	±16V	±.25% of FSR	±7.81mV
	8	±8V	±.25% of FSR	±3.9mV
	16	±4V	±.25% of FSR	±1.95mV
	32	±2V	±.25% of FSR	±976µV
	64	±1V	±.25% of FSR	±488µV
	128	±0.5V	±.25% of FSR	±244µV
256	±0.25V	±.25% of FSR	±122µV	
512	±0.125V	±.25% of FSR	±61µV	

Input Impedance: 500KΩ either input to ground
1MΩ differential

Input bias current: 10µA for a 10V input, single channel

Normal mode voltage: 100V peak, without damage

Common mode voltage: 60V peak, without damage

Common mode rejection: 60db @ Gain=1; 1KΩ unbalance

Channel-to-channel crosstalk rejection: 100db

Gain temperature coefficient: 100ppm/°C

Offset temperature coefficient: 100µV/°C

A/D Characteristics

Type: Successive approximation

Resolution: 12-bit

Monotonicity: ±2 LSB

Conversion Time: 71.4µs

Calibration

Calibration cycle: Verify yearly in the field

Calibration method: Digital calibration with scale and offset constant per channel and gain range.

USB Interface

Connector: USB

Max. data transfer rate: 14,400 samples per second

Analog Outputs

Number of channels: 2

Resolution: 12 bits

Integral Nonlinearity: ±2 LSB

Output Noise: 250µVrms

Output Current: ±300µA

Output short circuit current: 15mA

Voltage output slew rate: Load = 40pF: 0.44 V/µs

Output voltage swing: 0V to 1.25V

Startup time: 10µs

Digital I/O

Channels: 4 bi-directional ports

Output voltage levels: Min. "1" 3V @ 2.5mA sourcing
Max. "0" 0.4V @ 2.5mA sinking

Output current: Max. source, -2.5 mA
Max. sink, 2.5mA

Input voltage levels: Min. required "1" 2V
Max allowed "0" 0.8V

General

Input connectors: Two, 8 position terminal blocks

Operating Environment: 0°C to 70°C

Enclosure: Molded ABS plastic

Dimensions: 2.6L × 2.6W × 1.1D inches
66L × 66W × 28D mm.

Weight: 3 oz. (85 gr.)

Power Requirements

USB Models: 80mA max. @ 5 VDC. No external power required. Power derived from communications cable.

Scanning Characteristics

Max. throughput sample rate: 14,400 Hz

Min. throughput sample rate: 0.0137334 Hz

Timing accuracy: 100 ppm of sample rate

Max. scan list size: 6 entries

Sample buffer size: 2kb

DI-158 Analog Inputs (Typical)

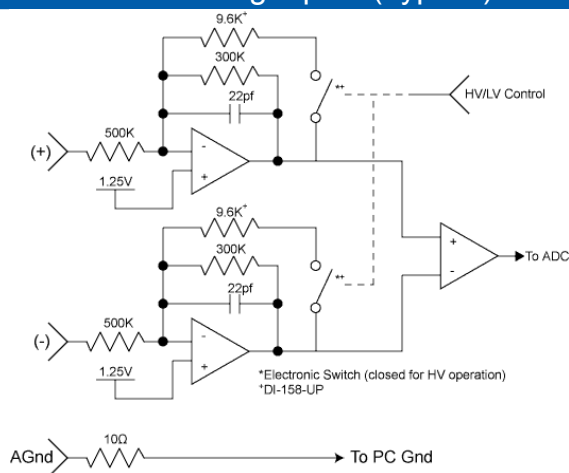

Input Impedance = 500KΩ either input to 1.25V, 1MΩ Differential

Ordering Guide

Description	Order Number
DI-158U Starter Kit DI-158 with USB interface.	DI-158U
DI-158UP Starter Kit DI-158 with USB Interface and high programmable gain/voltage range.	DI-158UP
WINDAQ/HS-158 High speed WINDAQ software. Record at the speed of the instrument.	WINDAQ/HS-158