



DI-148U

8-Channel USB Data Acquisition Starter Kit

DI-148U-SP

USB Data Acquisition Starter Kit with Two String Pot Inputs

DI-158 Series

USB Data Acquisition Starter Kit with 4 Fixed Differential Channels

User's Manual

Manual Revision L

⚠ CAUTION ⚠

READ BEFORE CONNECTING INPUT SIGNALS

The data acquisition device you have purchased and are about to use is **NOT** an **ISOLATED** product. This means that it is susceptible to common mode voltages that could cause damage to the device. **SUCH DAMAGE IS NOT COVERED BY THE PRODUCT'S WARRANTY.** Please read the following carefully before deploying the product. Contact DATAQ Instruments Support at 330-668-1444 for all questions.

This product can tolerate a maximum applied voltage of only $\pm 20V$ peak without damage. Although you may be certain that the signal you want to measure is lower than this level, a common mode voltage (CMV) with an unknown value may combine with your signal of interest to exceed this $\pm 20V$ limit. In such instances, the product will be damaged. Verify a CMV does not exist before connecting signals and acquiring data with your device. Use the following procedure to check for CMV:

1. **DO NOT** connect your data acquisition device to the device under test. If the device under test is connected to your data acquisition device, disconnect it.
2. Connect your data acquisition device to the appropriate interface on your PC (USB, Ethernet, RS-232 Serial, or Parallel Printer Port).
3. Apply power to your data acquisition device, your PC, and the device under test.
4. Use a digital voltmeter to make the following measurements:
 - a. Measure the voltage (both the AC and DC range) between the ground terminal of your data acquisition device and Signal+ of the device under test. This measurement should not exceed the Full Scale Range of your data acquisition device.
 - b. Measure the voltage (both the AC and DC range) between the ground terminal of your data acquisition device and Signal- of the device under test. This measurement should be at or very near 0 Volts.
 - c. Measure the voltage (both the AC and DC range) between the ground terminal of your data acquisition device and Common of the device under test. This measurement should be at or very near 0 Volts.
5. Should ANY of these measurements exceed their recommendation **DO NOT CONNECT SIGNALS** to the data acquisition device. A common mode voltage may exist that could destroy the instrument. You **MUST** determine the source of the CMV and eliminate it before taking any measurements.

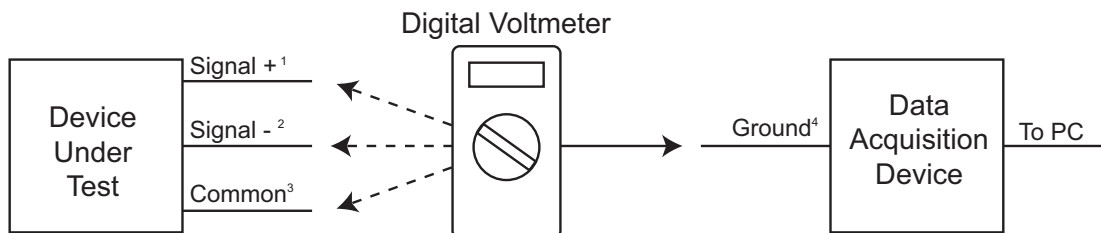

¹Measured signal is not to exceed the Full Scale Range of your data acquisition device.

²Measured signal must be at or very near 0 volts.

³Measured signal must be at or very near 0 volts.

⁴Connect to AGND (Analog Ground) port on DI-148 or DI-158 instruments.

Table of Contents

Warranty and Service Policy	iii
CAUTION	v
1. Introduction	1
Features	1
Analog Inputs	1
Digital Input and Output	2
Software	2
WinDaq® Recording and Playback Software	2
DATAQ Instruments Hardware Manager	3
Help	3
2. Specifications	5
DI-148 Analog Inputs	5
DI-158 Analog Inputs	5
A/D Characteristics	6
Analog Outputs (DI-158 Series only)	6
Scanning Characteristics	6
Digital I/O	7
Calibration	7
USB Interface	7
General	7
3. Installation	9
Installing WinDaq Software and the DATAQ Instruments Hardware Manager	9
Connecting the Instrument to Your Computer	10
Activation of WinDaq/High Speed Option	11
DATAQ Instruments Hardware Manager	11
4. Connecting Input Signals	13
DI-148U Connections	13
DI-148U-SP Connections	14
Calibrating String Pot Inputs	15
DI-158 Series Connections	17
Connecting to Ground	17
Port Designations	17
Connecting Signals	18
Digital I/O	18
Taking Process Current Measurements with a DI-158	19
5. Analog Input Diagram	21
DI-148U	21
DI-148U-SP	21
DI-158 Series	22

1. Introduction

This manual contains information designed to familiarize you with the features and functions of the DI-148U, DI-148U-SP, and the DI-158 Series data recording modules. These high-end Starter kits contain features and functionality normally reserved for more expensive data acquisition systems.

Features

The **DI-148U** data acquisition instrument is a portable data recording module that communicates through your computer's USB port. Power is derived from the interface port so no external power is required. Features include:

- 8 single-ended analog inputs.
- Six digital I/O for Remote control.
- $\pm 10\text{V}$ full scale measurement range.
- 14,400 samples per second maximum sampling rate.

The **DI-148U-SP** data acquisition instrument is a portable data recording module designed specifically for use with String Pots that communicates through your computer's USB port. Power is derived from the interface port so no external power is required. Features include:

- 2 string pot inputs plus 2 single-ended general purpose analog inputs.
- Six digital I/O for Remote control.
- $\pm 10\text{V}$ full scale measurement range.
- 14,400 samples per second maximum sampling rate.

The **DI-158** data acquisition instrument is a portable data recording module that communicates through your computer's USB port. Features include:

- 4 fixed differential analog inputs.
- 4 digital I/O for Remote control.
- Programmable Gain option allowing 10 different gain settings from $\pm 64\text{V}$ FS measurement range to $\pm 0.125\text{V}$ FS measurement range (depending on model).
- Up to 14,400 samples per second maximum sampling rate.

Analog Inputs

The **DI-148U** features eight single-ended analog channel inputs located on a single eight-position screw terminal block for easy connection and operation. The 10-entry input scan list allows you to scan any sequence of input channels at any software-configurable channel setting. Note: The DI-148U does not support Gain.

The **DI-148U-SP** features two string pot inputs (three terminals each: ground, voltage, wiper) and two single-ended analog channel inputs located on a single eight-position screw terminal block for easy connection and operation. The 6-entry input scan list allows you to scan any sequence of input channels at any software-configurable channel setting. Note: The DI-148U-SP does not support Gain.

The **DI-158 Series** features four differential channel inputs located on a single eight-position screw terminal block for easy connection and operation. The 6-entry input scan list allows you to scan any sequence of input channels at any software-configurable gain setting. Standard models (DI-158U) feature 4 programmable gain ranges at a full scale

range of ± 10 Volts while the DI-158 Programmable Gain option (DI-158UP) allows 10 gain ranges with a full scale range of ± 64 Volts.

DI-158U		DI-158UP	
Gain	Range	Gain	Range
1	$\pm 10V$	1	$\pm 64V$
2	$\pm 5V$	2	$\pm 32V$
4	$\pm 2.5V$	4	$\pm 16V$
8	$\pm 1.25V$	8	$\pm 8V$
		16	$\pm 4V$
		32	$\pm 2V$
		64	$\pm 1V$
		128	$\pm 0.5V$
		256	$\pm 0.25V$
		512	$\pm 0.125V$

Utilize the functionality of WINDAQ software to experience all the features encased in these small, inexpensive instruments.

Digital Input and Output

The DI-148U and DI-148U-SP contain six software-programmable digital lines (bits) for input/output operations; the DI-158 Series Instruments contain four. These lines provide an interface for the transfer of data between user memory and a peripheral device connected to the instrument. Digital inputs can monitor alarms or sensors with TTL outputs, while digital outputs can drive TTL inputs on control or measurement equipment. Remote control can be utilized with bits 0 and 1 (for location see “Chapter 4. Connecting Input Signals”) using WINDAQ software. The digital I/O may be enabled as Channel 9 using a DI-148U or Channel 5 using a DI-148U-SP or DI-158 model in WINDAQ software.

Software

All software required to record and playback waveforms is included with the purchase of any DI-148 or DI-158 Series data acquisition starter kit.

WINDAQ[®] Recording and Playback Software

WINDAQ Acquisition and WINDAQ Waveform Browser allow you to record and playback data acquired through your instrument. WINDAQ software is an invaluable resource to record and analyze your data.

WINDAQ Acquisition software can be used to record waveforms directly and continuously to disk while monitoring a real time display of the waveforms on-screen. It operates and displays waveform signals in real time at the full sample rate of the instrument being used. There are two versions of WINDAQ Acquisition software available for use with DI-148 and DI-158 Instruments: WINDAQ/Lite and WINDAQ/HS (High Speed) option. WINDAQ/Lite is free but is restricted to recording rates of 240 Hz. WINDAQ/HS option is an extra-cost option allowing you to record data at the speed of your data acquisition system. When you install the software, a trial version of WINDAQ/HS is automatically installed allowing you to run the software for a limited time. Activation is required for continued use to ensure compliance with the Software License Agreement. WinDAQ Acquisition software is accessed via the **Dataq Instruments Hardware Manager** located in the Program group as specified during installation.

WINDAQ Waveform Browser playback software (also known as “WWB”) offers an easy way to review and analyze acquired waveforms. A built-in data file translator allows the user to display multiple waveforms acquired by WINDAQ Acquisition software or any of a wide range of data acquisition packages. The software’s disk-streaming design allows data files of any length to be graphically displayed rapidly, in normal or reverse time directions. Seven standard cursor-based measurements, frequency domain, and statistical analysis functions help simplify waveform analysis and interpretation. WINDAQ Waveform Browser is free and installed when installing WINDAQ Software.

DATAQ Instruments Hardware Manager

This software can be found in the Start menu under the WINDAQ program group called **DATAQ Instruments Hardware Manager**. Access WINDAQ Acquisition software, Digital I/O setup, and more in this easy-to-use point and click environment. View the Help files by clicking on View Help in the Help menu or by pressing F1.

Help

All WINDAQ software utilizes context-sensitive help. Help may be accessed through the Help menu or by pressing the F1 key with any pull-down menu item selected. This will take you directly to the Help topic most relevant to that particular function or feature. Help topics discuss in detail each function available in the software.

2. Specifications

DI-148 Analog Inputs

Number of Channels:	DI-148U: 8 DI-148U-SP: 2 String Pot and 2 General Purpose
Channel Configuration:	Single-Ended
Voltage Measurement Range:	DI-148U and DI-148U-SP General Purpose Channels: $\pm 10\text{V}$ Full Scale DI-148U-SP String Pot Channels: 2.4VFS
Accuracy:	$\pm 0.25\%$ of FSR
Resolution:	DI-148U and DI-148U-SP General Purpose Channels: $\pm 19.5\text{mV}$ DI-148U-SP String Pot Channels: $\pm 7.4\text{mV}$
Input Impedance:	200K Ω
Input bias current:	50 μA for a 10V input, single channel
Maximum normal mode voltage:	20V peak to peak
Channel-to-Channel crosstalk rejection:	-60db
Gain temperature coefficient:	100ppm/ $^{\circ}\text{C}$
Offset temperature coefficient:	.5 $\mu\text{V}/^{\circ}\text{C}$
Output Voltage (DI-148U-SP):	String Pot Channels: 2.43 typical

DI-158 Analog Inputs

Number of Channels:	4
Channel Configuration:	Fixed Differential
Input Impedance:	500K Ω either input to ground 1M Ω differential
Input bias current:	10 μA for a 10V input, single channel
Normal mode voltage:	100V peak, without damage
Common mode voltage:	60V peak, without damage
CMR:	60db @ Gain=1; 1K Ω unbalance
Channel-to-Channel crosstalk rejection:	100db
Gain temperature coefficient:	100ppm/ $^{\circ}\text{C}$
Offset temperature coefficient:	100 $\mu\text{V}/^{\circ}\text{C}$
Accuracy:	$\pm 0.25\%$ of FSR

Voltage Measurement Range (Full Scale) and Resolution:

	Gain	Range	Resolution
DI-158U	1	$\pm 10\text{V}$	4.88mV
	2	$\pm 5\text{V}$	2.44mV
	4	$\pm 2.5\text{V}$	1.22mV
	8	$\pm 1.25\text{V}$	0.61mV

DI-158UP	1	±64V	±31.3mV
	2	±32V	±15.6mV
	4	±16V	±7.81mV
	8	±8V	±3.90mV
	16	±4V	±1.95mV
	32	±2V	±976μV
	64	±1V	±488μV
	128	±0.5V	±244μV
	256	±0.25V	±122μV
	512	±0.125V	±61μV

A/D Characteristics

Type: Successive approximation
 Resolution: DI-148: 10-bit
 DI-158: 12-bit
 Monotonicity: ±2 LSB
 Conversion Time: DI-148: 70μs
 DI-158: 71.4μs

Analog Outputs (DI-158 Series only)

Number of channels: 2
 Resolution: 12 bits
 Integral Nonlinearity: ±2 LSB
 Output Noise: 250μVrms
 Output Current: ±300μA
 Output short circuit current: 15mA
 Voltage output Slew rate:
 Load = 40pF: 0.44 V/μs
 Output voltage swing: 0V to 1.25V
 Startup time: 10μs

Scanning Characteristics

Maximum throughput sample rate: 14,400 Hz
 Minimum throughput sample rate: 0.0137334 Hz
 Timing accuracy: 100 ppm of sample rate
 Maximum scan list size: DI-148: 10 entries
 DI-158: 6 entries
 Sample buffer size: 2kb

Digital I/O

Channels:	DI-148: 6 bi-directional DI-158: 4 bi-directional
Output voltage levels:	Minimum “1”, 3V @ 2.5mA sourcing; Maximum “0”, 0.4V @ 2.5mA sinking
Output current:	Maximum source, -2.5mA; Maximum sink, 2.5mA
Input voltage levels:	Minimum required “1”, 2V; Maximum allowed “0”, 0.8V

Calibration

Calibration Cycle:	One year
Calibration method:	Digital calibration with scale and offset constant per channel.

USB Interface

Connector Type:	USB
Maximum data transfer rate:	14,400 samples per second

General

Input connectors:	Two 8 position terminal blocks
Operating Environment:	0°C to 70°C
Enclosure:	Molded ABS plastic.
Dimensions:	2.6D x 2.6W x 1.1H in. 66D x 66W x 28H mm.
Weight:	3 oz. (85 gr.)
Power Requirements:	80mA max. @ 5 VDC. No external power required—power derived from communications cable.

3. Installation

The following items are included with each WINDAQ Starter Kit. Verify that you have the following:

- A DI-148 or DI-158 Instrument.
- The *WINDAQ Resource* CD-ROM.
- USB cable.
- Screwdriver for securing your signal leads into the screw terminal inputs.

If an item is missing or damaged, call DATAQ Instruments at 330-668-1444. We will guide you through the appropriate steps for replacing missing or damaged items. Save the original packing material in the unlikely event that your unit must, for any reason, be sent back to DATAQ Instruments.

Installing WINDAQ Software and the DATAQ Instruments Hardware Manager

The *WINDAQ Resource CD* contains all the software required for use with all DI-148 and DI-158 instruments. This installation includes the following software: WINDAQ Acquisition software (WINDAQ/HS (High Speed) option Trial version), WINDAQ Waveform Browser playback software, and the Dataq Instruments Hardware Manager.

Note: For continued use of WINDAQ/HS option, the software must be activated—see “Activation of WinDaq/High Speed Option” below for details.

1. Disconnect all DATAQ Instruments USB devices from your Computer.



2. Insert the *WINDAQ Resource CD* in your drive. The installation software should start automatically within 20 seconds. If it does not, start it manually by double-clicking the Setup application (setup.exe) located on the root of the *WINDAQ Resource CD*.
3. In the “What do you want to do?” window, select “Install WinDaq Software” and click **OK**.

4. In the “Installing Software” window, select the “Install Software for DI-148, DI-158, DI-710, DI-715B, and DI-718B(x) instruments” option and click **OK**.
5. In the “WinDaq Installation” dialog box, select the “Install Software” option and click **OK** to continue. If you wish to view the hardware documentation you may do so now by clicking on the appropriate radio button. Documentation will be saved to your hard drive during this installation.
6. In the “Welcome!” box, click **OK** to continue.
7. Read the License Agreement. If you accept the terms, click **Accept and Continue**. If you choose not to accept, click on the **Do not accept and stop** button to end the installation.
8. When prompted, enter your registration information (name and company) in the appropriate text boxes and click **OK**. Confirm your registration information before continuing.
9. When prompted, specify the directory where you want to install your WINDAQ software. It is recommended that you accept the default. If you have already successfully installed a DI-148, DI-158, DI-710, DI-715B, or DI-718B instrument be sure to install to the same folder.
10. In the “Select an Interface” box select **USB** and click **OK**.
11. **DO NOT** connect your USB device or cable to your PC until installation is complete. If your device is currently connected, please disconnect it before continuing with this installation. Once your device is disconnected, click the **OK** button.
12. When prompted to Select a Program Manager Group specify a destination (or group window) in the Start Menu for WINDAQ software icons. It is recommended that you accept the default.
13. In the “Installation Option” dialog box specify whether you want all users to have access to WINDAQ software or just the current User. Click Yes to allow all users to have access, click No to allow just the current user to have access.
14. After WINDAQ Software installs, you will be prompted to install WINDAQ/XL Trial Version and Advanced CODAS Analysis software. If you wish to install either software click on Yes in the appropriate dialog box. Follow the on screen prompts to complete installation.
15. Software installation is complete - you will now see a “Successful Installation” box - click **OK** to exit WINDAQ Installation.

You can now plug the device(s) into your PC and apply power (if required). You do not need to re-install this software when installing more DI- 148 or DI-158 USB devices to your PC.

Click on the appropriate program group (specified above — default is Start > Programs > WINDAQ) and click on “DATAQ Instruments Hardware Manager” to run WINDAQ software. All DATAQ Instruments software is located in the same program group.

Connecting the Instrument to Your Computer

DI-148 and DI-158 instruments can be connected to your computer’s USB port using the provided cable. No external power is required. Connect one end of the communications cable to the instrument port and the other to your PC’s port.

IMPORTANT: DO NOT CONNECT INPUT SIGNALS TO YOUR DEVICE UNTIL YOU HAVE READ “CAUTION” on page v.

Note: Use a powered USB hub or a USB port on your PC. Non-powered USB hubs may not have sufficient power to run the instrument.

Activation of WINDAQ/High Speed Option

Activation is required for continued use of WINDAQ/High Speed option to ensure compliance with the Software License Agreement. The Software License Agreement can be found in the WINDAQ Software manual or in the WINDAQ program group (License.txt). The WINDAQ/HS option may be activated through the **Help** menu by clicking on **Unlock WINDAQ/HS** or by waiting for the trial version to expire. Trial versions are good for 40 High Speed recording sessions. The High Speed version may be purchased after the trial period expires through our online store or by phone. For help or for questions regarding Activation and/or the Software License Agreement, contact DATAQ Instruments Customer Support.

DATAQ Instruments Hardware Manager

The DATAQ Instruments Hardware Manager is installed when installing any DI-148 or DI-158 instrument. This software allows you to effectively manage multiple devices installed on the same PC. The DATAQ Instruments Hardware Manager may be accessed through the Windows Program Manager Group as specified during installation (default is *Start > Programs > WINDAQ > DATAQ Instruments Hardware Manager*). All available devices will automatically appear in the list box when you run the software. For help with the DATAQ Instruments Hardware Manager access the Help Files using either the Help menu item or by pressing the F1 key to access context-sensitive help.

4. Connecting Input Signals

All input signal connections are made to the two 8-port screw terminals. Each terminal is labeled directly on the instrument case. **DO NOT CONNECT INPUT SIGNALS TO YOUR DEVICE UNTIL YOU HAVE READ “CAUTION” on page v.**

DI-148U Connections

Refer to the following for screw terminal port identification.

AGnd: Analog Ground

D5: Digital I/O bit 5

D4: Digital I/O bit 4

D3: Digital I/O bit 3

D2: Digital I/O bit 2

D1: Digital I/O bit 1—Remote Event Marker*

D0: Digital I/O bit 0—Remote Start/Stop*

DGnd: Digital Ground

Analog Channels: 8 Single-ended analog channels

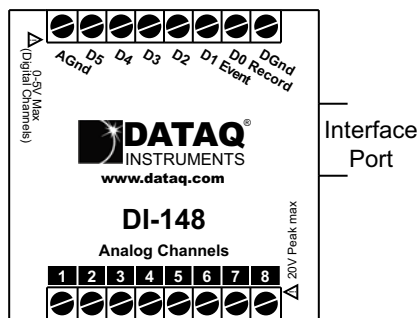

*When using WINDAQ Acquisition software you **must** enable either Channel 1 or Channel 9 as the Digital Input to use the Remote Control Functions.

Use the following diagram to connect Input Channel 1.

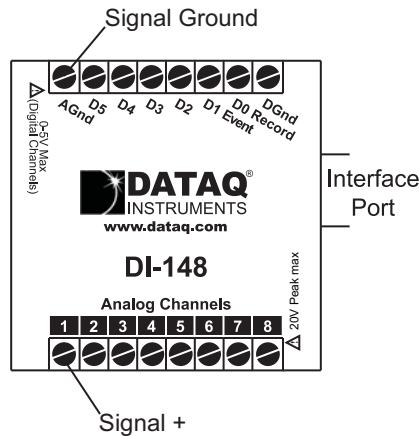

DI-148U-SP Connections

Refer to the following for screw terminal port identification.

AGnd: Analog Ground

D5: Digital I/O bit 5

D4: Digital I/O bit 4

D3: Digital I/O bit 3

D2: Digital I/O bit 2

D1: Digital I/O bit 1—Remote Event Marker*

D0: Digital I/O bit 0—Remote Start/Stop*

DGnd: Digital Ground

SP1 and SP2 (string pot channels): 2 channels with 3 terminals each (voltage(V), wiper(W), ground(⏚))

3 and 4 (general purpose analog channels): 2 Single-ended analog channels (for connection follow DI-148U instructions above)

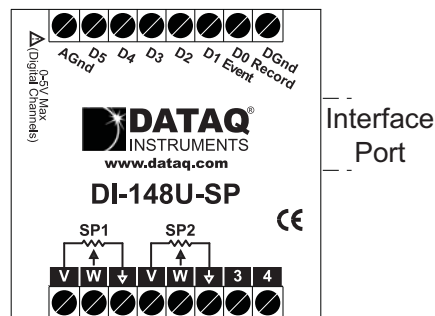

*When using WINDAQ Acquisition software you **must** enable either Channel 1 or Channel 5 as the Digital Input to use the Remote Control Functions.

Use the following diagram to connect String Pot Channel 1 (SP1). Refer to your String Pot manual for correct wiring.

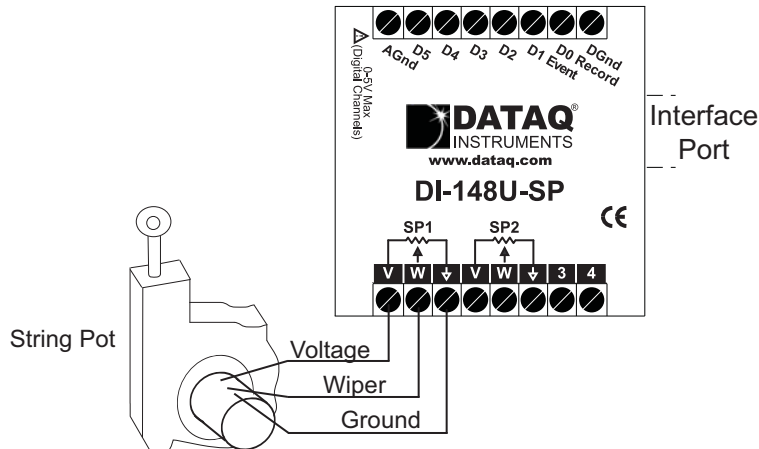

Note: Location of wires or wire terminals will vary based on specific model of String Pot. Refer to String Pot hardware guide for correct wiring.

Calibrating String Pot Inputs

The String Pot Inputs **must** be calibrated before acquiring signals from the DI-148U-SP in WINDAQ Acquisition Software. Using the High/Low method and the full scale range of the instrument ($\pm 10V$) is suggested.

1. Enter the Low Calibration.
 - a. In the **Edit** menu click on **Low Calibration...**

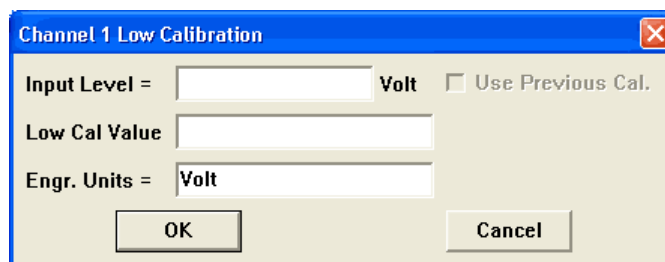

- b. Enter **-10** for the **Input Level** and **0** (the string pot at position 0) for the **Low Cal Value**. Enter the Engr. Units using the proper measurement quantifier (i.e., the Low Cal Value, be it inches, centimeters, etc.) based on the length of your displacement cable.
2. Enter the High Calibration.

- a In the Edit menu click on **High Calibration...**

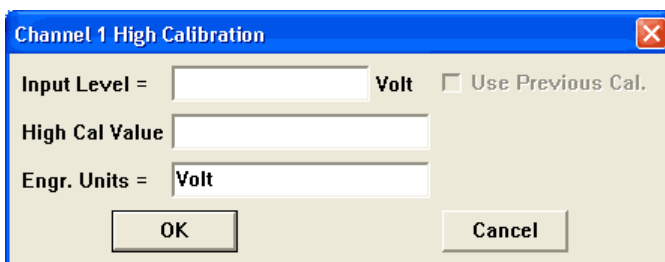

Channel 1 High Calibration

Input Level = [] Volt Use Previous Cal.

High Cal Value []

Engr. Units = [Volt]

OK Cancel

- b Enter **10** for the **Input Level** and the greatest length of the displacement cable for the **High Cal Value**. Enter the Engr. Units using the proper measurement quantifier (i.e., the Low Cal Value, be it inches, centimeters, etc.) based on the length of your displacement cable.

DI-158 Series Connections

Connecting to Ground

The ground connection on the I/O terminal strip (labelled AGnd) should *always* be connected to a signal ground, if one is not inherently made through analog or digital signal connections. Without this connection, the DI-158 does not have a return path which could lead to inaccurate measurements. Under no circumstances should the DI-158 be used in a measurement situation where it will experience common mode voltages in excess of ± 30 VDC or peak AC (the device's full-scale range without damage).

Port Designations

Refer to the following for connections.

AGnd: Analog Ground

DAC0: Digital to Analog converter

DAC1: Digital to Analog converter

D3: Digital I/O bit 3

D2: Digital I/O bit 2

D1: Digital I/O bit 1—Remote Event Marker*

D0: Digital I/O bit 0—Remote Start/Stop*

DGnd: Digital Ground

Analog Channels: 4 Differential Analog Channels—“+” is the positive terminal; “-” is the negative terminal

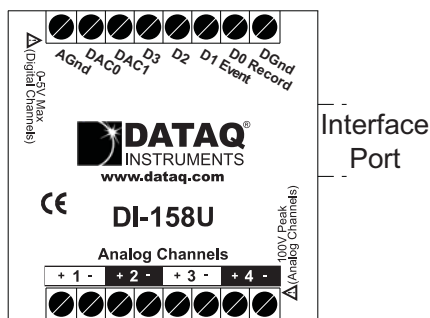

*When using WINDAQ Acquisition software you **must** enable either Channel 1 or Channel 5 as the Digital Input to use the Remote Control Functions.

Use the following diagram to connect differential input Channel 1.

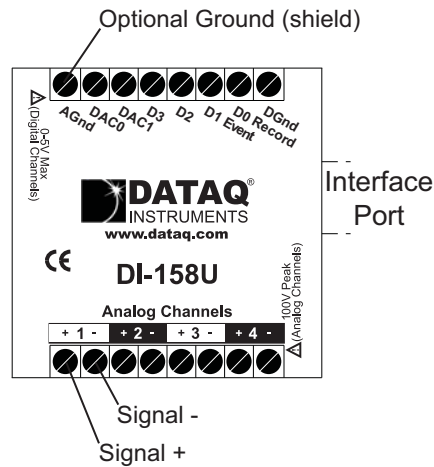

Connecting Signals

To connect signals to the DI-148 or DI-158:

1. Insert the stripped end of a signal lead into the desired terminal directly under the screw.
2. Tighten the pressure flap by rotating the screw clockwise with a small screwdriver. Make sure that the pressure flap tightens only against the signal wire and not the wire insulation. Do not over-tighten.
3. Tug gently on the signal lead to ensure that it is firmly secured.

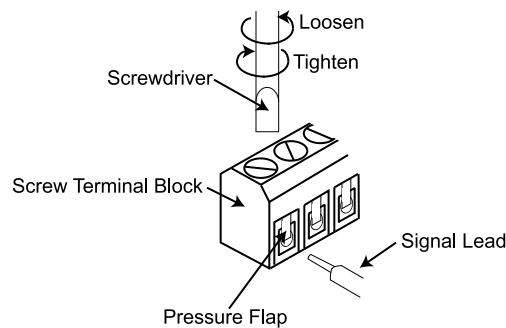

When an input signal is connected and WINDAQ Acquisition software is run, WINDAQ's real time display immediately reveals the input waveform on your computer's monitor.

Digital I/O

To avoid using up an analog channel enable the Digital I/O as Channel 9 on the DI-148 or Channel 5 on the DI-148U-SP or DI-158 in WINDAQ Software. See the WINDAQ manual or Help Files for information on enabling a Digital channel.

Taking Process Current Measurements with a DI-158

When measuring process current it's important to consider that a potential difference (common mode voltage) may exist between the loop power supply ground and that of the data acquisition device. To check for such a voltage place a volt meter between the two grounds.

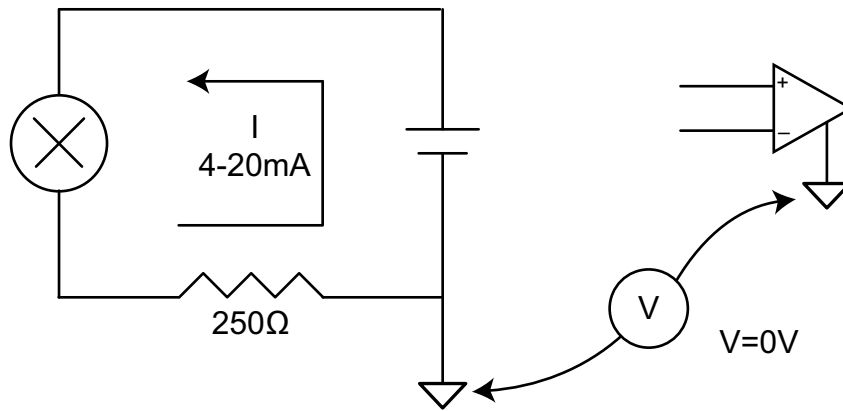

Ideally 0V will be present between the power supply and data acquisition grounds.

Should a common mode voltage (AC or DC) exist, determine the sum of your input signal and the common mode voltage (CMV). If this sum exceeds the maximum rating of your device (see “2. Specifications”) you must determine the source of the CMV and eliminate it before taking any measurements. This may be as simple as plugging the loop power supply and data acquisition device into the same wall outlet.

Another common mistake when acquiring process current data is to measure across the shunt resistor on the high side of the current loop. In doing so you're exposing your data acquisition device to the full power supply voltage.

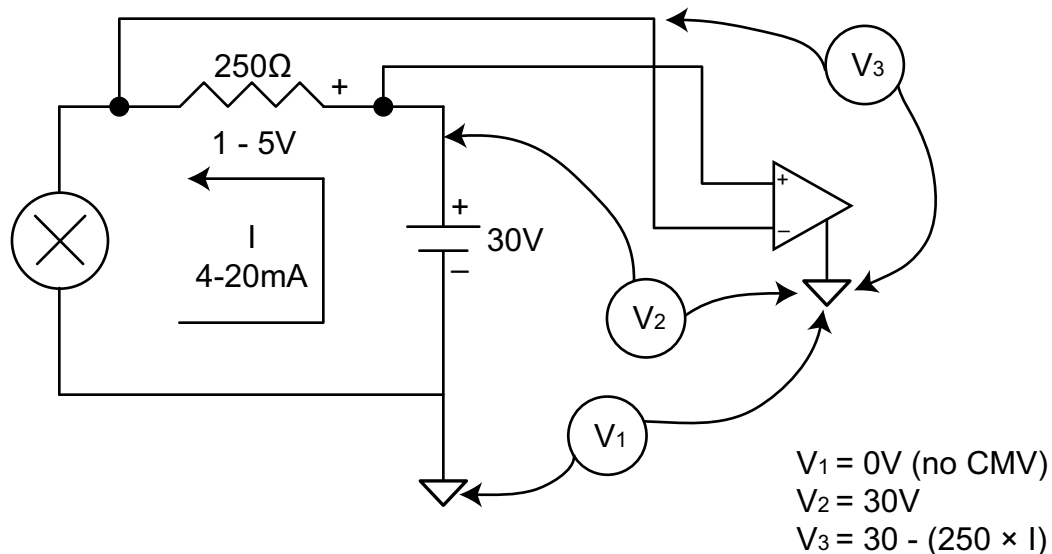

Assuming that the grounds are common, measuring across the shunt resistor on the high side of the circuit exposes the data acquisition device to the power supply voltage.

To avoid this, place the shunt resistor on the low side of the circuit (Figure 4).

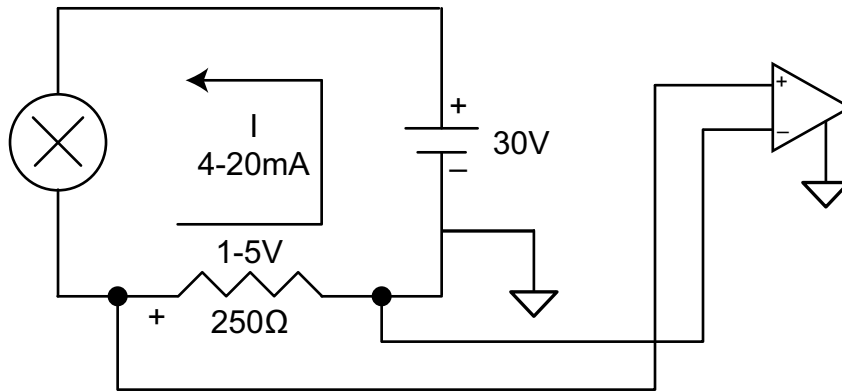

With the shunt resistor on the low side of the circuit the data acquisition device sees only the voltage across the resistor. This allows you to measure just the voltage across the shunt resistor (1-5V).

The same principles apply to a multi-sensor configuration. Use the following diagram for proper multi-sensor process measurement connections.

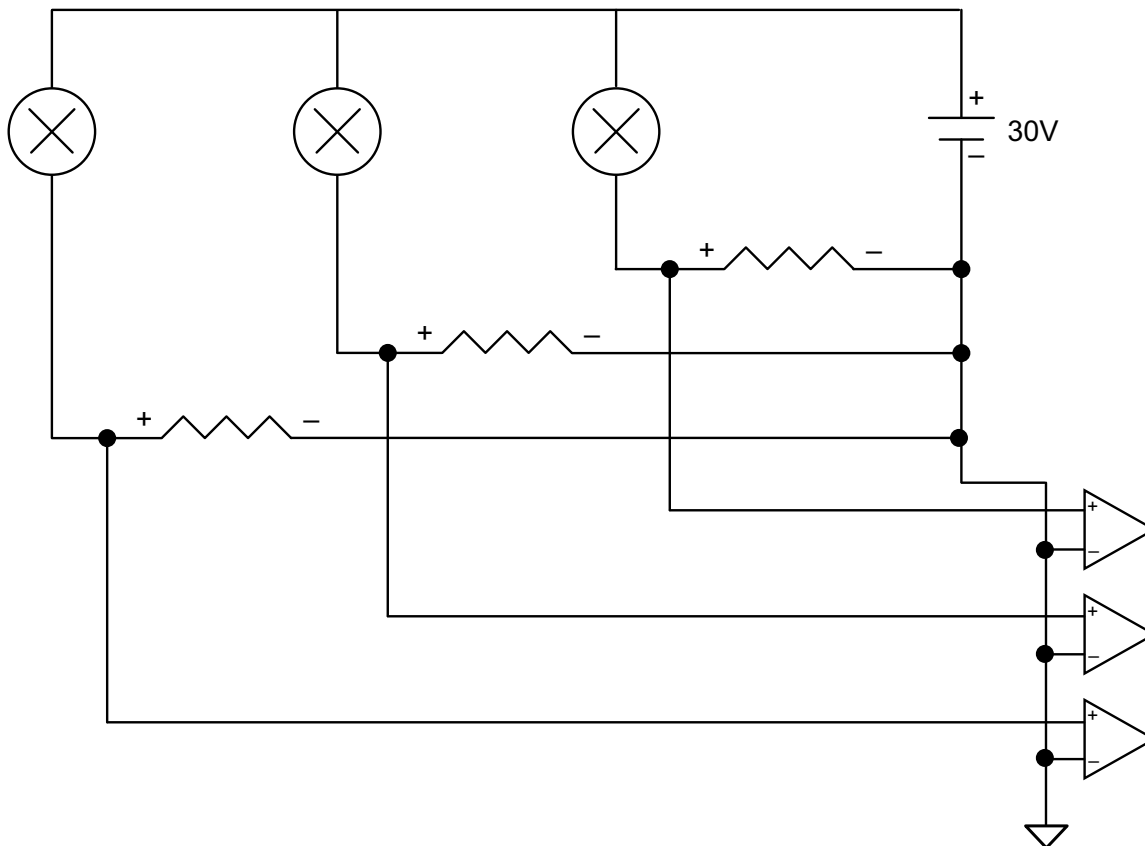

With proper precautions, process current measurements can be made with little if any risk to your data acquisition equipment. To eliminate the risk all together consider a data acquisition product that provides isolation (DI-5B32-XX, DI-5B42-XX, DI-8B32-XX, DI-8B42-XX). For more information about isolation see the application notes on the web: “Process Current Data Acquisition” and “Learn the Importance of Isolation in Four Easy Lessons.”

5. Analog Input Diagram

DI-148U

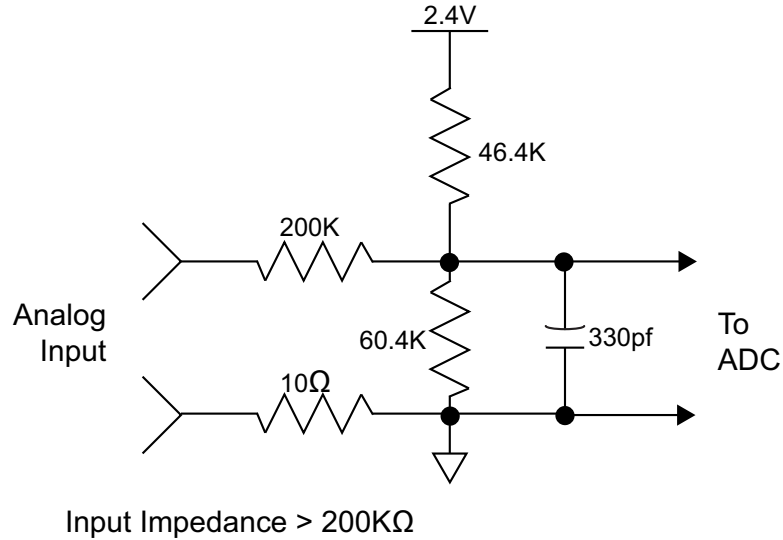

DI-148U-SP

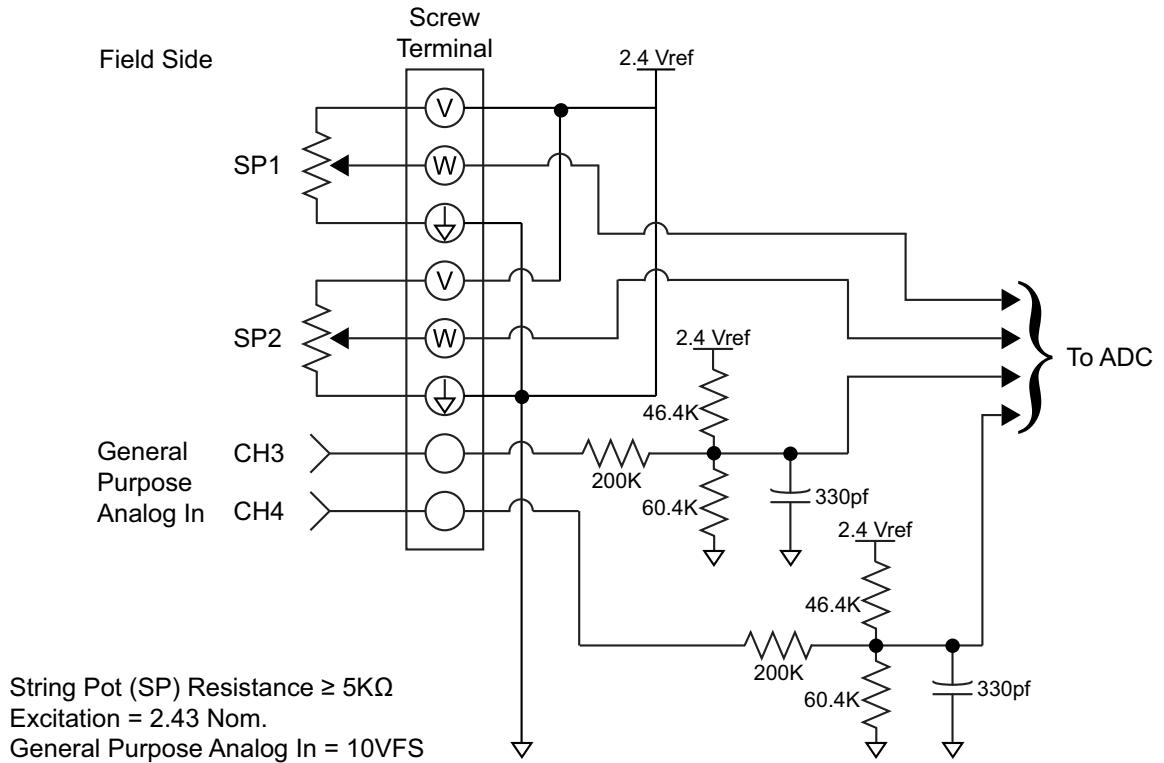

DI-158 Series

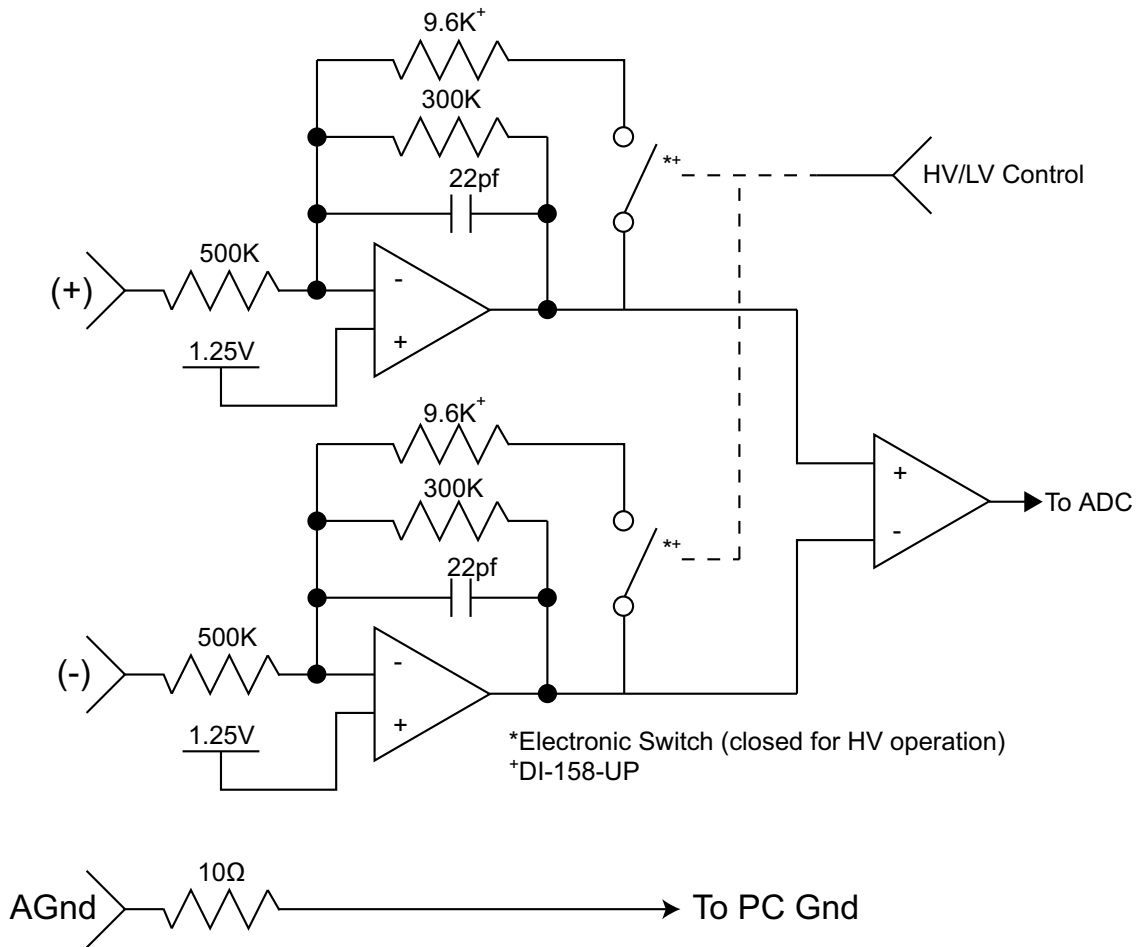

Input Impedance = 500KΩ either input to 1.25V, 1MΩ Differential

Warranty and Service Policy

Product Warranty

DATAQ Instruments, Inc. warrants that this hardware will be free from defects in materials and workmanship under normal use and service for a period of 90 days from the date of shipment. DATAQ Instruments' obligations under this warranty shall not arise until the defective material is shipped freight prepaid to DATAQ Instruments. The only responsibility of DATAQ Instruments under this warranty is to repair or replace, at its discretion and on a free of charge basis, the defective material.

This warranty does not extend to products that have been repaired or altered by persons other than DATAQ Instruments employees, or products that have been subjected to misuse, neglect, improper installation, or accident.

DATAQ Instruments shall have no liability for incidental or consequential damages of any kind arising out of the sale, installation, or use of its products.

Service Policy

1. All products returned to DATAQ Instruments for service, regardless of warranty status, must be on a freight-prepaid basis.
2. DATAQ Instruments will repair or replace any defective product within 5 days of its receipt.
3. For in-warranty repairs, DATAQ Instruments will return repaired items to the buyer freight prepaid. Out of warranty repairs will be returned with freight prepaid and added to the service invoice.

Copyright © 2010 by DATAQ Instruments, Inc. The Information contained herein is the exclusive property of DATAQ Instruments, Inc., except as otherwise indicated and shall not be reproduced, transmitted, transcribed, stored in a retrieval system, or translated into any human or computer language, in any form or by any means, electronic, mechanical, magnetic, optical, chemical, manual, or otherwise without expressed written authorization from the company. The distribution of this material outside the company may occur only as authorized by the company in writing.

DATAQ Instruments' hardware and software products are not designed to be used in the diagnosis and treatment of humans, nor are they to be used as critical components in any life-support systems whose failure to perform can reasonably be expected to cause significant injury to humans.

DATAQ, the DATAQ logo, and WINDAQ are registered trademarks of DATAQ Instruments, Inc. All rights reserved.