

# IMR 400

## Flue-Gas Conditioning System



IMR Environmental Equipment, Inc.

---

## Installation of Gas Conditioning Unit

- Choose a place for the gas-conditioning unit and then mount it. The best place for the gas-conditioning unit is within 1m of the gas-sampling probe. Leave space around the housing.

**Note:** Do not extend the hose between the probe and the gas conditioning unit with any kind of tubing, because condensed water will cause a problem.

- Connect the heated hose to the gas-conditioning unit and connect the plug of the heated hose with its socket on the enclosure.
- The PVC hose (approx. 5m) has to be connected to the specific gas outlet of the gas conditioning unit and the gas inlet of the gas-controlling unit.
- The On/Off-switch for the conditioning unit is on the outside of the enclosure. The unit is heating the hose when the green LED is on.
- The unit has a power cord already installed. Connect the power cord to AC when the installation is complete.

## Technical Data:

Power supply:	230V / 60Hz
Wall mounted housing:	390 x 290 x 170 mm
Ready for operation:	20 min
Ambient temperature:	5°C - 40°C
Storage temperature:	-25°C - +65°C
Fuse:	4A / 230VAC

### Schematic: Connection

#### Bottom of 400 Dryer

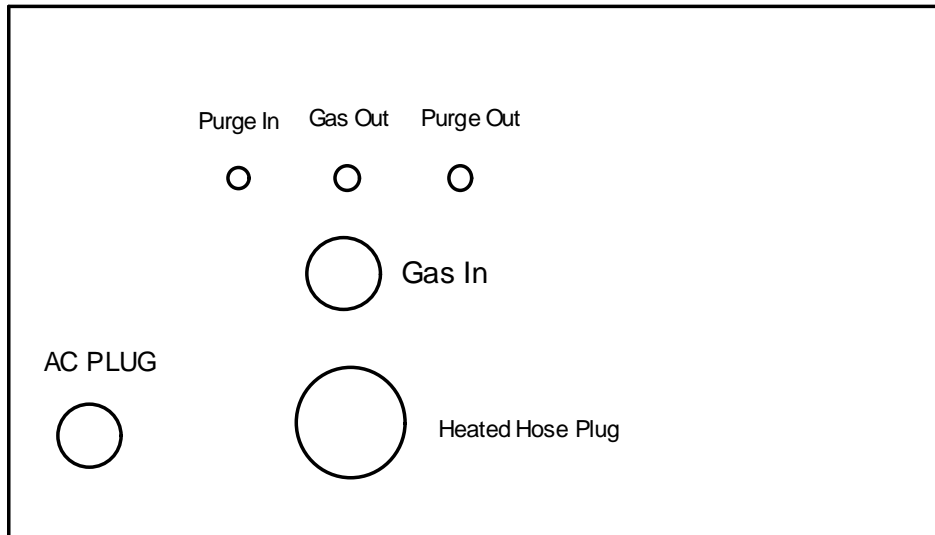

### How close to the Gas Control Unit Should the Gas Conditioning Unit Be Setup?

- Install the gas conditioning unit 15feet from the Gas Controller Unit
- Leave space around the housing for the different outlets and inlets.
- Connect the PVC hose with the IMR 400.
- A power cord is already installed. Connect the power cord to AC when the installation is complete.

---

## WARRANTY

The company IMR Environmental Equipment International, Inc., 3634 Central Ave., St. Petersburg, FL, 33711, USA states the following:

IMR, as manufacturer hereby grants the following worldwide IMR guarantee for an IMR unit purchased from an authorized dealer.

1. The IMR guarantee shall entitle every IMR customer to demand a free replacement or repair of the defect parts of the IMR unit from any IMR dealer authorized for the respective IMR unit.
2. The IMR guarantee shall be granted on the factory new unit and shall commence on the date of the delivery of the original IMR unit to the customer. It shall last for a period of one year regardless of the type and the intensity of use and regardless of any change of owner, which may occur during this guarantee period.

The IMR guarantee shall refer to absence of faults with respect to the state of the art nature of the sold unit in terms of material and finish. The guarantee for all parts fitted during the twelve month guarantee period shall end with the unit guarantee.

3. After the establishment of a material or production fault by IMR or the authorized IMR dealer, the faults will be eliminated by means of free repair or replacement. Replaced parts shall become the property of IMR.
4. No guarantee claims may be made for maintenance and setting work, cleaning or other utility materials required for the function of the unit and other wear parts unless they have a direct bearing on work performed under the guarantee.
5. The terms and conditions for the acknowledgement of this guarantee shall be the presentation of the fully completed guarantee card which must contain the confirmation from the authorized IMR dealer on its delivery and, if applicable, the prescribed maintenance work.
6. The IMR guarantee shall only be applicable if
  - a. The IMR unit has been maintained in accordance with the instructions issued by the manufacturers and the operating instructions by an authorized IMR dealer;
  - b. Only original IMR spare parts have been used for any repairs;
  - c. The unit has been used properly, the operating instructions observed and the unit has not been used for a purpose other than the one for which it has been designed;
  - d. The IMR unit has been left in its original design and meets the original IMR specifications;

- e. The fault is not due to external influences or use for a purpose other than the one for which it has been designed;
  - f. Exclusively authorized IMR dealers have made repairs to the IMR unit;
  - g. The IMR unit has been sent to an authorized IMR dealer immediately after the fault was discovered.
7. Electrochemical and NDIR sensors are included in the guarantee.

---

## Company Information

IMR Environmental Equipment, Inc.  
St. Petersburg, FL 33711  
USA  
Phone: 727-328-2818  
Fax: 727-328-2826  
E-mail: [info@imrusa.com](mailto:info@imrusa.com)  
[www.imrusa.com](http://www.imrusa.com)